

Application Note

Backreflection vs Return Loss – What Difference Does It Make?

Mark Berezny, Product Line Manager

When light is emitted into a fiber-optic component (ex: connector, fiber, coupler, etc.) some of the energy is transmitted, some is absorbed and some is reflected. In fiber-optic systems, reflected light is due to Fresnel reflections and Rayleigh scattering. Fresnel reflections occur at discrete components and are a result of air gaps, misalignment, and non-matching refractive indexes. Rayleigh scattering is a result of the variations in material density and compositional fluctuations which occur during fiber manufacturing.

Backreflection and Return Loss have been measured on components, connectors, patchcords and cables for years and remain to be two of the key parameters to define the reflections created by the device under test. However, some confusion remains in the industry between Backreflection and Return Loss, mostly due to misunderstanding the differences between the two.

Backreflection

Backreflection, also called Optical Return Loss (ORL), refers to the total effect of multiple reflections and scattering events in a fiber-optic system.

Backreflection caused by Rayleigh backscattering varies with the length and type of fiber. As can be seen in Figure 1 below, the longer the cable under test, the higher the backscattering. For example, backscattering of a typical 10m fiber is almost -60 dB. Backscattering is therefore limiting the possibility to measure Backreflection for long cables or components with long pigtailed.

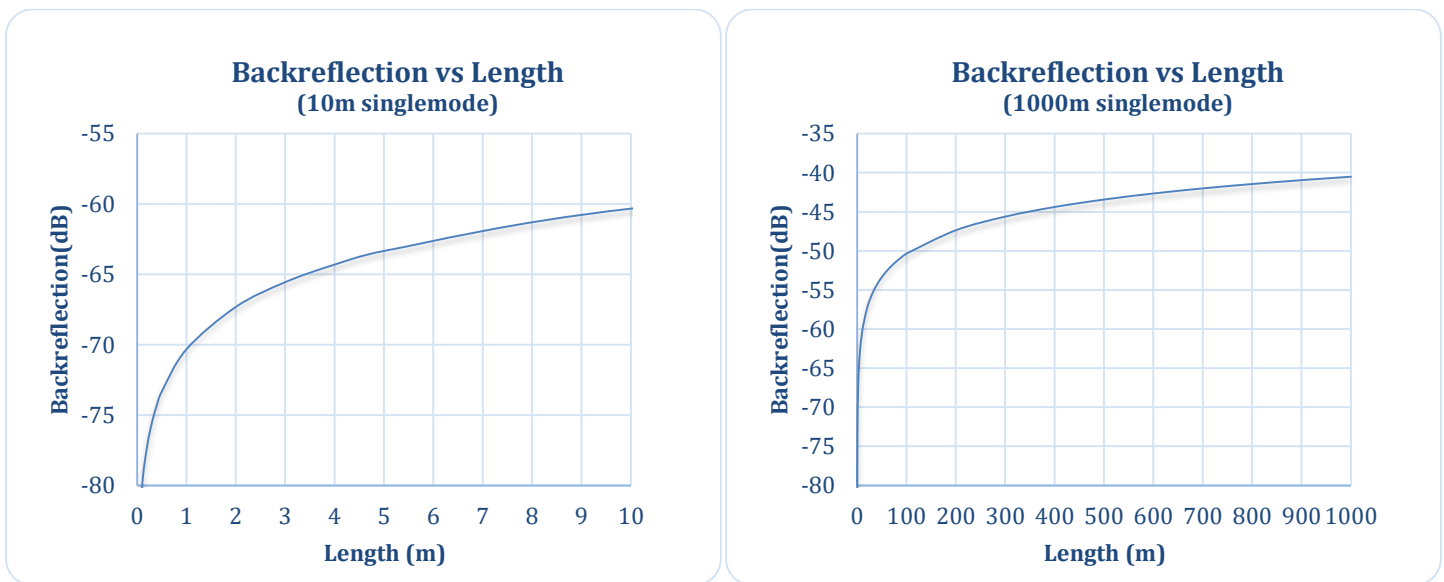

Figure 1 - Impact of Backscattering on Backreflection measurement

Application Note

Backreflection is measured using a technique commonly called Optical Continuous Wave Reflectometry (OCWR) which consists of sending a continuous-wave (CW) optical signal to a device under test (DUT) and measuring the total reflected power using a power meter in the return path. JGR's BR5 Backreflection meter has been designed to do exactly this.

When performing Backreflection (BR) measurements with the BR5, it is required to terminate the fiber at two different points. The termination can be done using a mandrel wrap, index matching block or an APC connector to air. The difference in Backreflection between the two termination points is then calculated and displayed by the meter to give the DUT Backreflection.

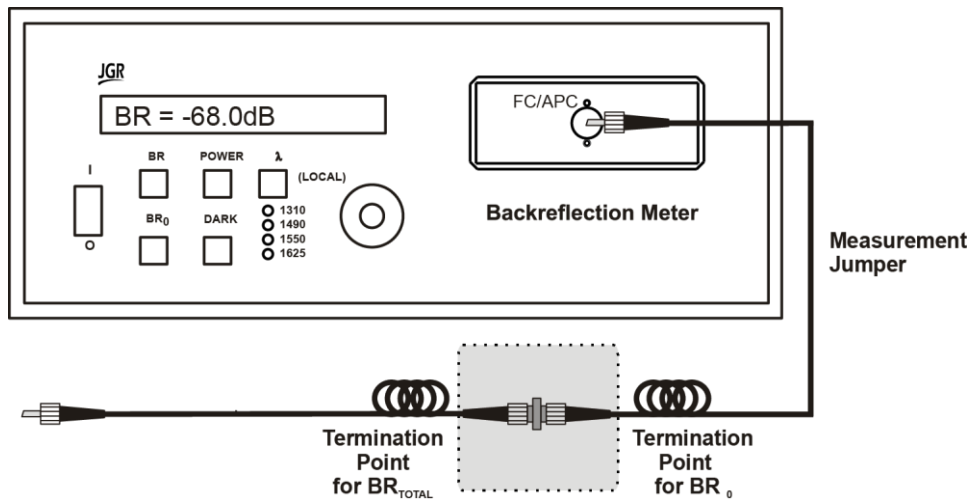

Figure 2 - Typical Backreflection measurement set-up

JGR'S BR5 is great for measuring the total backreflection of short DUTs where backscattering is not limiting the measurement. For example, a short 50cm patchcord as shown below in figure 3.

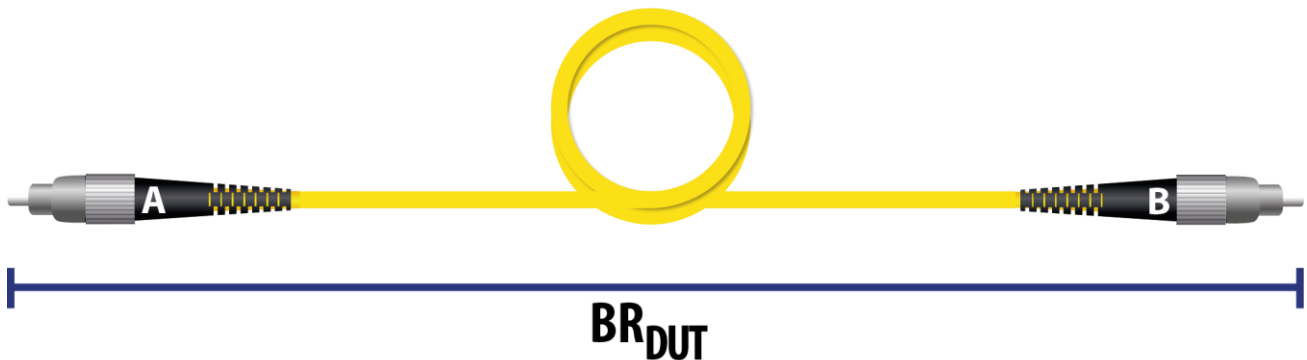

Figure 3 - BR_{DUT} of a 50 cm patchcord

Application Note

Return Loss

Return Loss, also called Reflectance, measures the amount of light reflected by a single discontinuity in a transmission line or optical fiber.

The MS12 Return Loss Meter, part of the JGR's MS12001 Cable Assembly Test System, uses a mandrel free approach based on optical time-domain reflectometry (OTDR). When using this method, no mandrel wraps are required and Return Loss (RL) is measured in two simple and easy steps. A reference needs to be taken with the reference test jumper and then a measurement with the DUT.

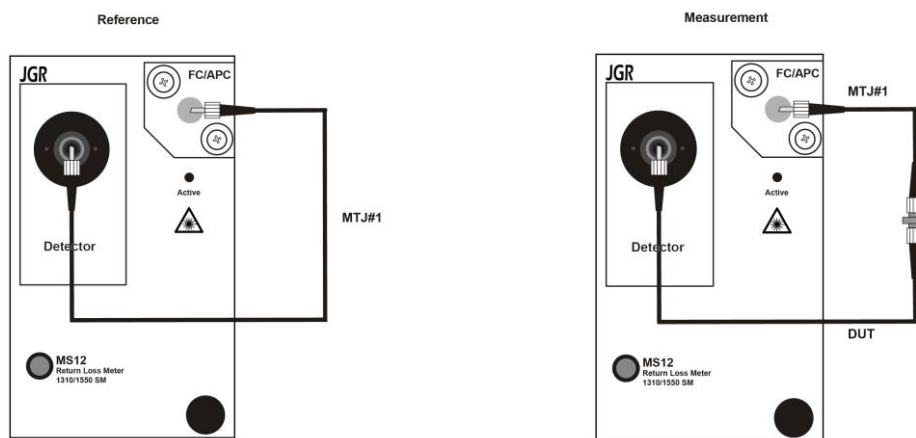

Figure 4 - Typical Return Loss measurement set-up

Return Loss (OTDR) can measure the discrete reflectance of the input and output connectors without the impact of fiber backscattering (RL_a and RL_b).

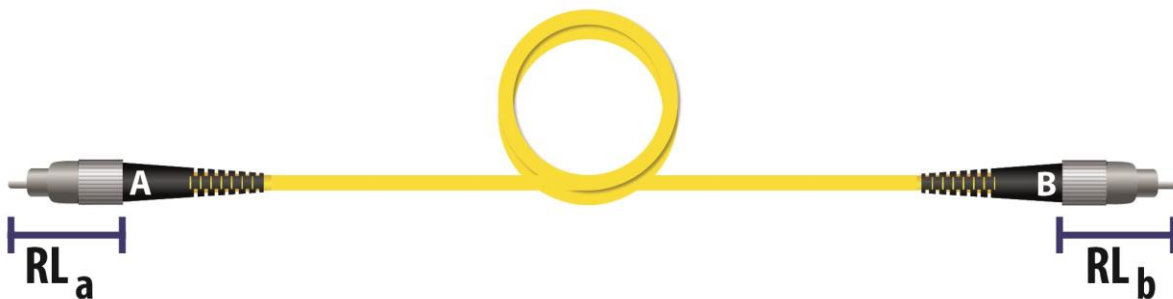

Figure 5 - RL_a and RL_b measurement using MS12

Application Note

Which Method to Choose?

Before selecting a measurement technique for cable assemblies or components, it is important to establish what is important for the application, the type of DUT and its characteristics since this information can highly influence the choice.

BR5/MBR5/PDL5 Backreflection Meters Backreflection (OCWR) Method



- Great for short DUTs where impact of backscattering is limited
- Simple and well known technology, up to 4 times faster than OTDR in some cases
- Some limitations when testing rigid cable or bend-insensitive fibers or very long length

MS12 Cable Assembly Test System Return Loss (OTDR) Method



- Perfect for long DUT since technology is not impacted by backscattering
- Allows for separate characterization of connector and DUT reflectance
- Compatible with almost any kind of DUT, including rigid cables and bend-insensitive fibers